

| Rev. | Zone | Revision description | Sign. | Date |
|------|------|-----------------------------|-------|------------|
| C | BOM | Added art. 61780 | GK | 06.05.2019 |
| D | BOM | Pos. 5, 6 | GK | 14.05.2019 |
| E | BOM | Remarks, Bolt M12x25 art no | GK | 04.10.2019 |

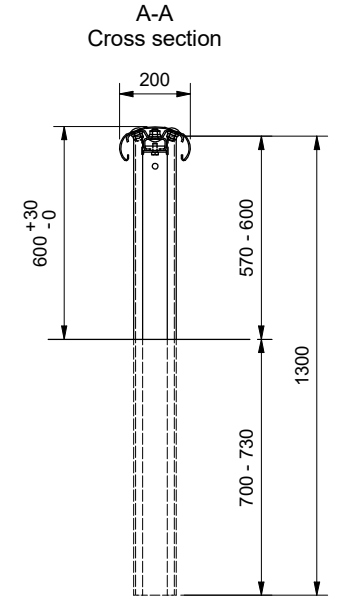
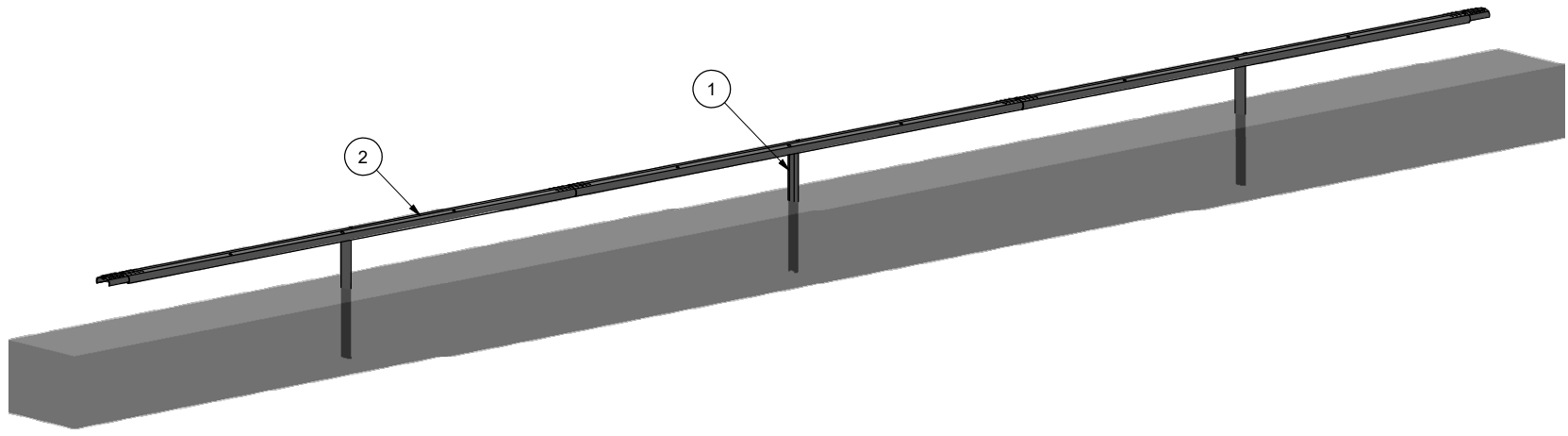
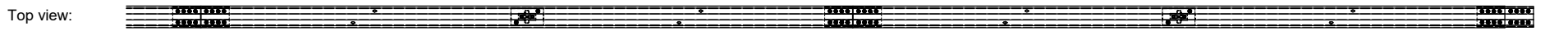
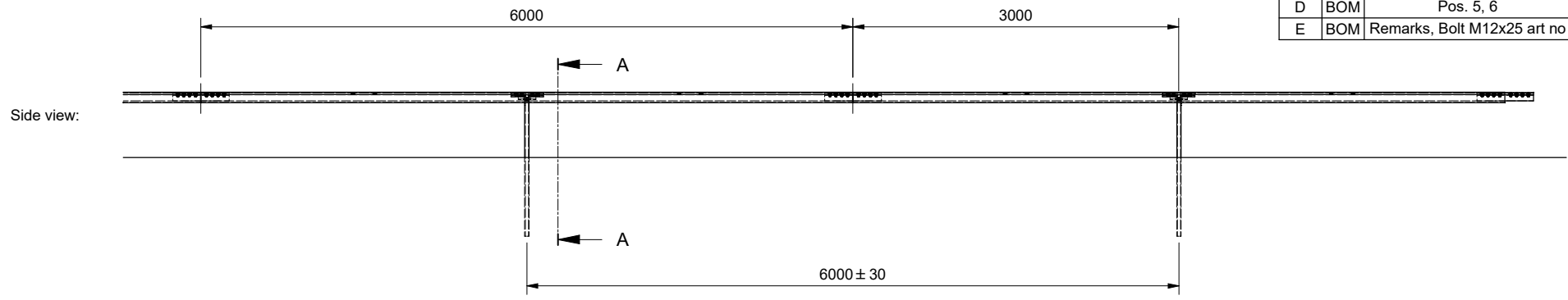

| 9 | 1/6 m | 61768 | Joint plate | 4,5 kg | 1pc. included in KIT 61740 |
|------|--------|-----------|--|---------|------------------------------|
| 8 | 1/6 m | 61786 | Top plate | 2 kg | 1pc. included in KIT 61740 |
| 7 | 1/6 m | 61789 | Bolt M12x25 DIN933 4.6 HDG | 0 kg | |
| 6 | 20/6 m | 692316000 | Flange nut M16 DIN 6923 8 Isofit HDG | 0,1 kg | 12pcs. included in KIT 61740 |
| 5 | 20/6 m | 61769 | Bolt M16x30 with rounded head 8.8 HDG | 0,1 kg | 12pcs. included in KIT 61740 |
| 4 | 1/6 m | 61787 | Mini C 65 | 0,7 kg | 1pc. included in KIT 61740 |
| 3 | 1/6 m | 61788 | T-washer | 0,2 kg | |
| 2 | 1/6 m | 61750 | Oval open profile 200x100x3 L=5995 cc3/6 | 52,6 kg | 1pc. included in KIT 61740 |
| 1 | 1/6 m | 61700 | C-post 120 L=1300 | 11 kg | |
| Pos. | Ant. | Art. no | Material type | Mass | Remarks |

For assembly details see system assembly drawing 5135700M.
Mass 12.5 kg/m

| | | | | | |
|---|------------|------------------|----|-------------|--------------|
| Date | 27.04.2019 | Constr./Drawn by | gk | Scale | A3 - 1 : 100 |
| Calculation | | Approved by | | | |
| Safeline-M Median Barrier Posts spacing c/c 6m, post L=1.3 m System drawing | | | | | |
| Reference: | | Replacement for | | Replaced by | |

Sheet no 1/1

VIKORSTA
a SAFEROAD company

5135700

Revision **E**

This drawing is our property and must not be used, copied, or made available to others without our consent.