

REGULATIONS
NO SHARP EDGES ALLOWED

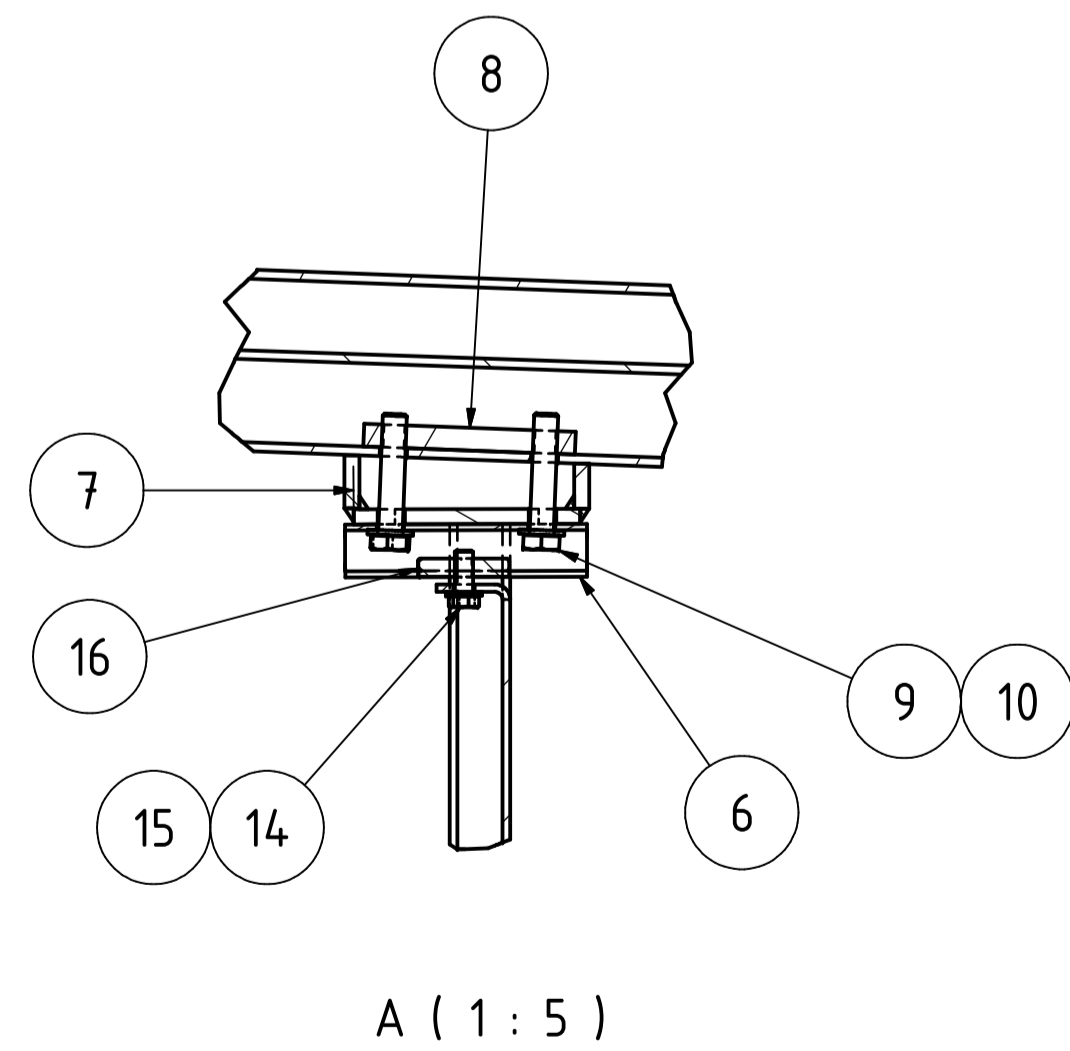
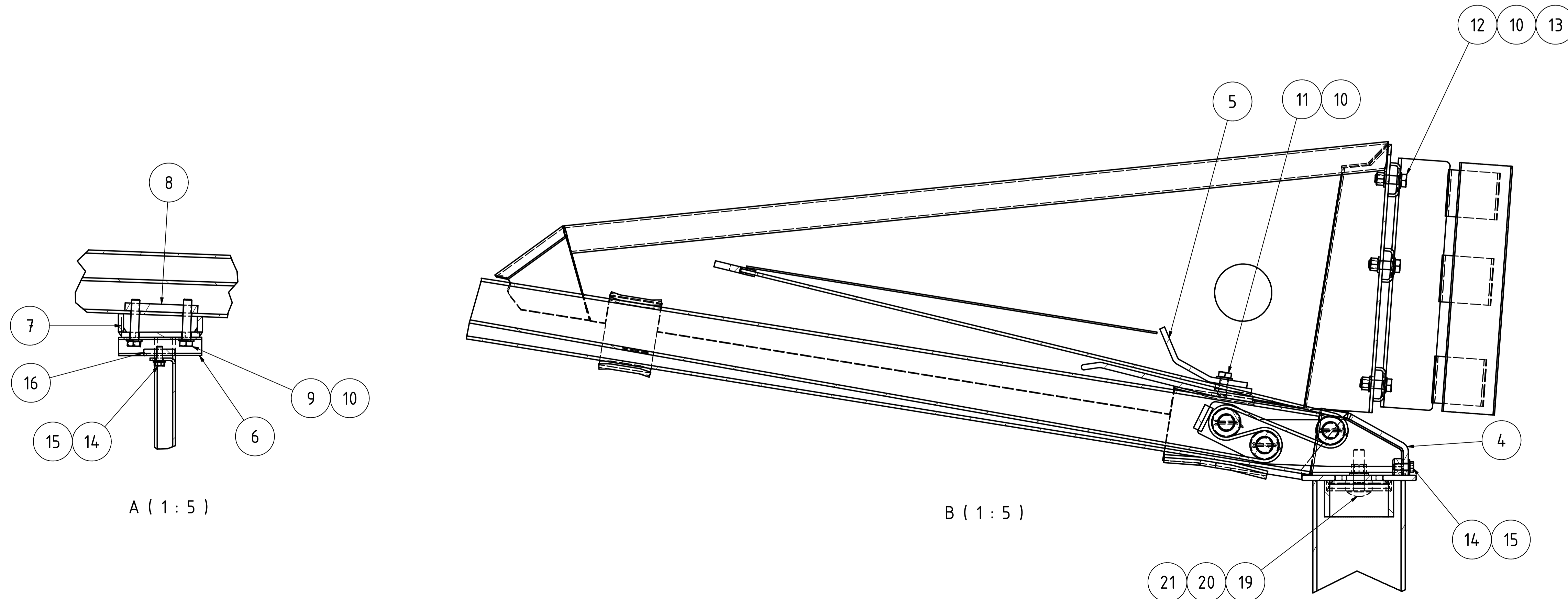
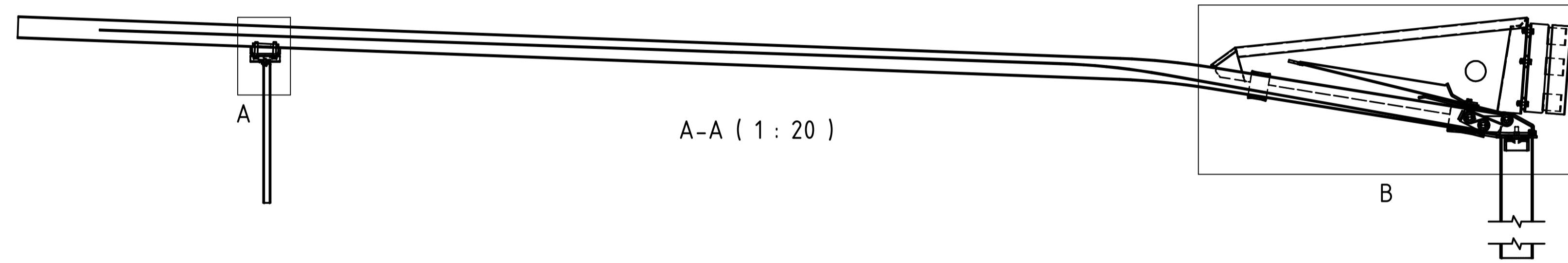
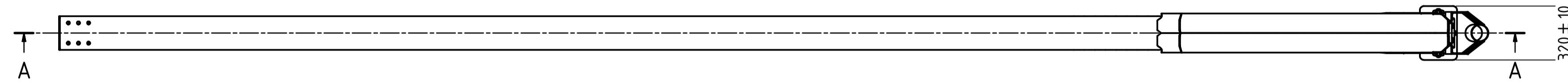
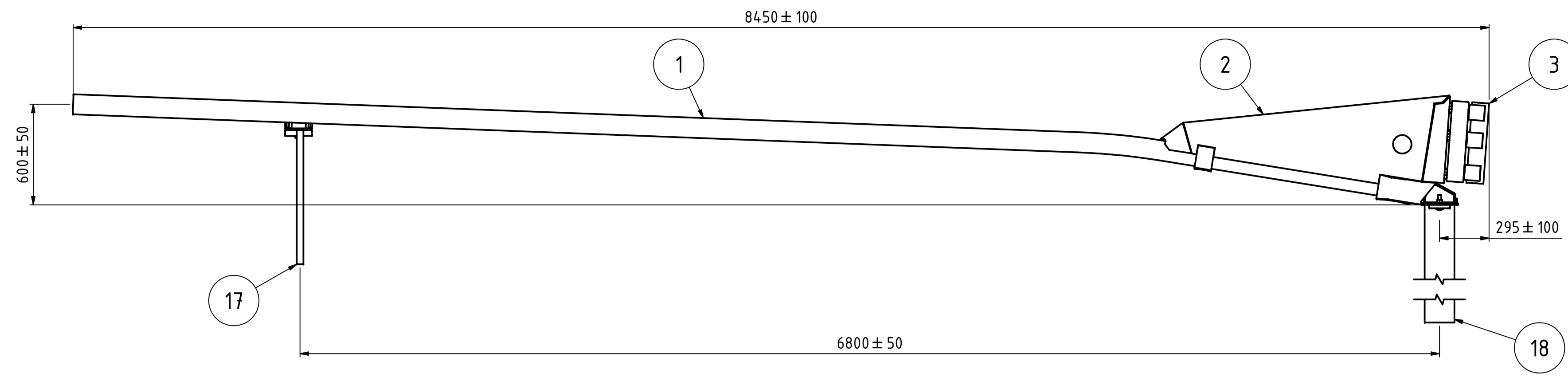

B (1 : 5)

Item No.	Qty.	Description	Material	Dimension	Note
21	2	NUT	8.	M20	
20	2	WASHER	HV 200	21 x 36	
19	2	MUSHROM HEAD SCREW	8.8	M20 x 80	
18	1	"NAIL"	S 355		8920531-CRT
17	1	C-POST	S 355		8920301-CRT
16	1	CONNECTOR PLATE M12	S 355	t=12	8920505-CRT
15	2	WASHER	HV 200	13 x 24	HDG
14	2	SCREW	8.8	M12 x 30	HDG
13	6	NUT	8.	M16	HDG
12	6	SCREW	8.8	M16 x 50	HDG
11	2	SCREW	8.8	M16 x 35	HDG
10	16	WASHER	HV 200	17 x 30	HDG
9	2	SCREW	8.8	M16 x 80	HDG
8	1	THREADED PLATE M16			8920092-CRT
7	1	DISTANCE, POST			8920090-CRT
6	1	C PROFILE 85x35x22.5x4			8920504-CRT
5	1	BRACKET, BRAKE BAND			8920015-CRT
4	1	SafeEnd BRAKE ASSEMBLY			89200501-CRT
3	1	DEFORMATION ELEMENT			8920061-CRT
2	1	SafeEnd BOX			8920062-CRT
1	1	SafeEnd TUBE			8920030-CRT

Design.	Drawn	Copied	Control.	Stand.	Appr.	Scale	Replaces	Replaced by
	GLN							

birsta	Birsta SafeEnd ASSEMBLY	File name: 8920080-CRT	Date: 2012-11-30
www.birsta.eu		Drawing no: 8920080-CRT	Rev.